

Max Angle 60 Degree

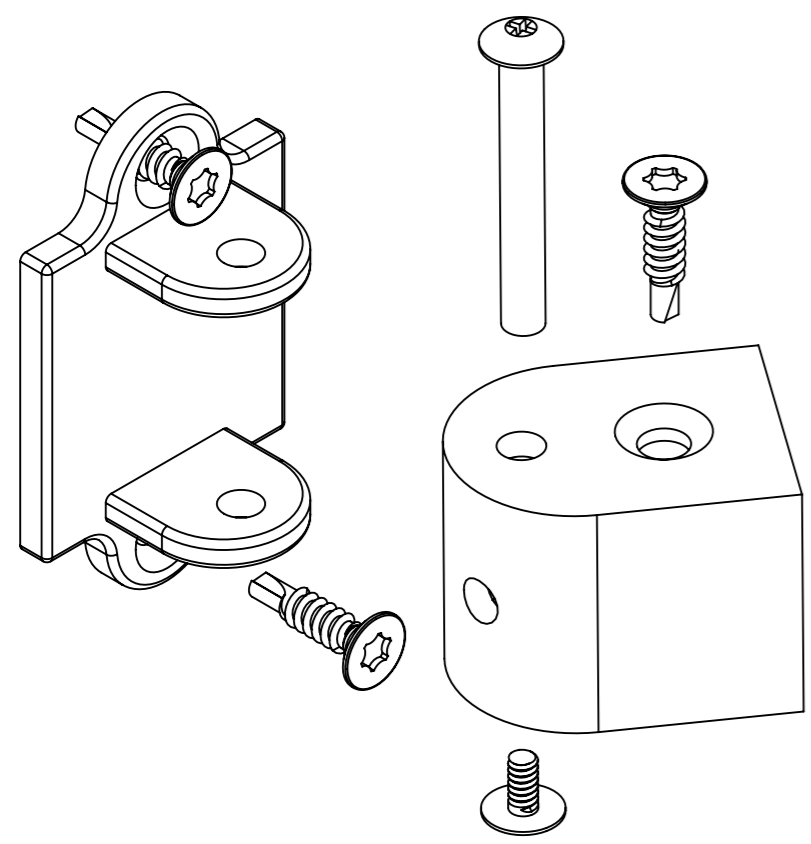

25mm Superior Horizontal Angle Bracket
Supplied With Fixings & Used With
Standard Panels & Posts

NOTES

- 1) FINISH - PRE GALVANISED + ZINC PHOSPHATE + E COAT + UV POWDER COATING
- 2) COLOUR & TEXTURE - BLACK SAND
- 3) PRODUCT FITS FORTITUDE 25 X 25 X 1.5 RAILING PANELS & STANDARD POSTS

| | | | | | |
|---|--|--|--|---|--|
| | | | | NOTES: | |
| | | | | Customer Drawing Information | |
| <small>UNLESS OTHERWISE SPECIFIED ALL DIMENSIONS ARE IN MILLIMETERS</small> | | | | DESCRIPTION: | |
| | | | | 25mm - Superior Corner Bracket - Black Sand / Box of 4 (Includes Fixings) | |
| | | | | PART NO: | |
| | | | | 64SCB25B | |
| | | | | DWG NO: | |
| | | | | N/A | |
| | | | | A3 | |
| | | | | SCALE:1:1 | |