

25mm Choice Universal Bracket
Supplied With Steel & Wood Fixings

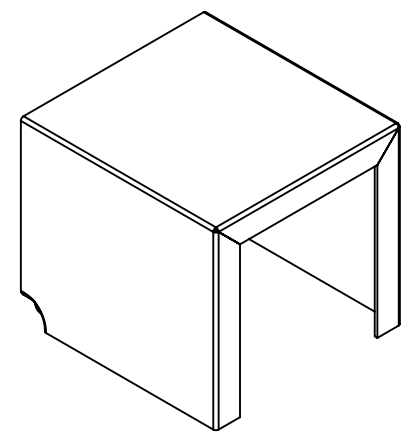
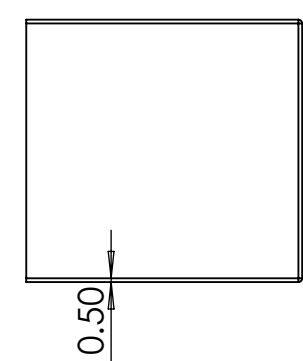

NOTES

- 1) FINISH - PRE GALVANISED + ZINC PHOSPHATE + E COAT + UV POWDER COATING
- 2) COLOUR & TEXTURE - BLACKSAND
- 3) PRODUCT FITS FORTITUDE 25 X 25 X 1.5 RAILING PANELS & STANDARD POSTS.

				NOTES:		
				Customer Drawing Information		
<small>UNLESS OTHERWISE SPECIFIED ALL DIMENSIONS ARE IN MILLIMETERS</small>				DESCRIPTION:		
				25mm - Choice Universal Bracket Pressed Steel		
				PART NO:		
				64CUB25B		
<small>DRAWN GC 29/06/2017</small>				DWG NO:		
				N/A		
<small>CHECKED</small>				A3		
				SCALE:1:1		
<small>REVISION B</small>				DO NOT SCALE DRAWING		
				SHEET 1 OF 1		
<small>MATERIAL: Mild Steel</small>				<small>WEIGHT: 0.08 Kg</small>		
<small>FINISH: Black Sand</small>				<small>GRIT SIZE: N/A</small>		